



SPECIALISTS FOR ULTRA HIGH FREQUENCY

---

# VAS-4163

## Dual Channel UHF/WNW

### Shipboard Antenna

---

PN: VD-17-00070-1

VALCOM'S VAS-4163 IS A DUAL CHANNEL, UHF/WNW ANTENNA. IT IS A RUGGED, SELF-SUPPORTING, VERTICALLY POLARIZED, BROADBAND ANTENNA COVERING THE FREQUENCY RANGE OF 225 MHz TO 400 MHz AND 400 MHz TO 2000 MHz. THIS LIGHT WEIGHT ANTENNA CAN BE USED IN EITHER THE TRANSMIT MODE OR THE RECEIVE MODE.

THE ANTENNA IS DESIGNED FOR USE UNDER THE SEVERE ENVIRONMENTAL CONDITIONS ENCOUNTERED IN A SHIPBOARD ENVIRONMENT.

THE TWO INDEPENDANT RADIATING ELEMENTS ARE HOUSED IN A SINGLE FIBREGLASS RADOME WITH AN INTEGRAL FIBREGLASS MOUNTING BASE.

THE TWO ANTENNA CHANNELS ARE HIGH POWER DIPOLES. THE UHF DIPOLE IS CAPABLE OF HANDLING POWER LEVELS OF UP TO 1 KW AVERAGE. THE WNW DIPOLE IS CAPABLE OF HANDLING POWER LEVELS UP TO 300 W AVERAGE. THE ISOLATION BETWEEN THE TWO CHANNELS IS GREATER THAN 25 dB. EACH CHANNEL EXHIBITS A NOMINAL INPUT IMPEDANCE OF 50 OHMS AND A VSWR OF 3.0:1 MAXIMUM AND 2.5:1 AVERAGE OVER THE ENTIRE FREQUENCY RANGE OF 225 MHz TO 2000 MHz.

THE ANTENNA HAS BEEN DESIGNED TO MEET THE VIBRATION REQUIREMENTS OF MIL-STD-167, TYPE I AND II, THE SHOCK REQUIREMENTS OF MIL-S-901 AND THE ENVIRONMENTAL REQUIREMENTS OF MIL-E-16400H.

**FEATURES:**

- BROADBAND
- LIGHTWEIGHT
- SHIPBOARD APPLICATIONS
- RECEIVING OR TRANSMITTING MODE
- WEATHERPROOF



# VAS-4163 UHF/WNW SHIPBOARD ANTENNA QUICK REFERENCE DATA

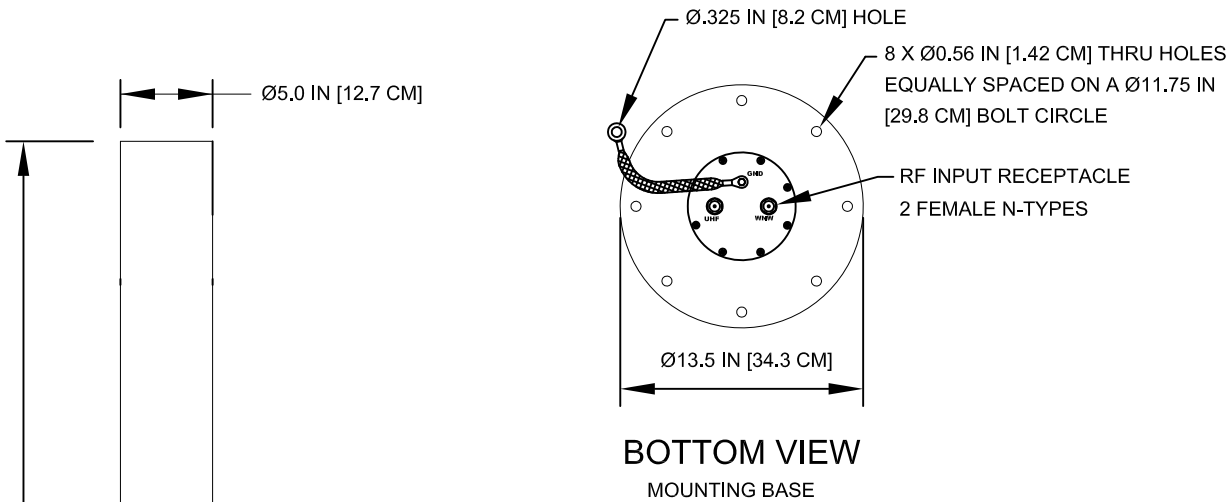

## ELECTRICAL CHARACTERISTICS

FREQUENCY RANGE	UHF: 225 MHz TO 400 MHz WNW: 400 MHz TO 2000 MHz
INPUT IMPEDANCE	50 OHMS NOMINAL
POLARIZATION	VERTICAL
POWER RATING	UHF: 1000 W AVERAGE WNW: 300 W AVERAGE
AZIMUTH COVERAGE	OMNIDIRECTIONAL
VSWR	UHF: 2.5:1 AVG 3.0:1 MAX WNW: 1.5:1 AVG 2.0:1 MAX
INPUT CONNECTION	N-TYPE RECEPTACLES

## MECHANICAL CHARACTERISTICS

ANTENNA OVERALL LENGTH	75 IN (190.5 CM)
ANTENNA WEIGHT	34.0 LBS (15.9 KG)
CENTRE OF GRAVITY	24 IN (61 CM) UP FROM BASE
OPERATING TEMPERATURE	-55°C TO +65°C
RADOME AND BASE FLANGE	EPOXY FIBREGLASS
FINISH	HAZE GRAY SILICONE ALKYD ENAMEL
VIBRATION	MIL-STD-167, TYPE 1
SHOCK	MIL-S-901C, GRADE A
HUMIDITY	MIL-STD-810E, PROCEDURE III

### NOTE:

1. DO NOT USE LEAD BASED PAINT TO TOUCH UP OR REPAINT ANTENNA

